

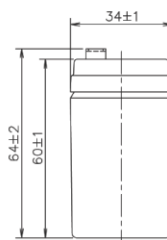

閥調式鉛酸蓄電池(VRLA)
Valve Regulated Lead Acid Battery

NP2.3-12

尺寸 DIMENSION

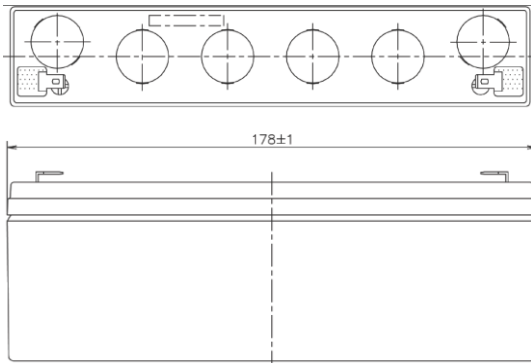

規範 Specification

- | | |
|---|--|
| <ul style="list-style-type: none"> ☑ 公稱電壓 Nominal Voltage : 12V ☑ 尺寸 Dimension <ul style="list-style-type: none"> 長度 Length : 178±1mm 寬度 Width : 34±1mm 高度 Case Height : 60±1mm 總高 Overall Height : 64±2mm ☑ 重量 Weight (約 Approx.) : 900 g ☑ 公稱容量 Nominal Capacity : 2.3AH / 20HR (25°C) ☑ 內部抵抗 Internal Resistance(Approx.) : 約 68 mΩ ☑ 最大充電電流 Max. Charge current : 0.575A ☑ 5秒最大放電電流
Max. Discharge current in 5 seconds : 34.5A ☑ 浮動充電 Float Charging : 13.65±0.15V (25°C) ☑ 端子 Terminal :
插入式端子 Faston tab : 187 / 250 | <ul style="list-style-type: none"> ☑ 操作溫度範圍 Operating Temperature Range <ul style="list-style-type: none"> 放電 Discharging -15°C to 45°C 充電 Charging -15°C to 45°C 放置 Storage -15°C to 45°C ☑ 期待浮充壽命 Expected float use life (25°C) : 3~5 years ☑ 容易保養 Easy Maintenance
不會洩漏電解液 No electrolyte leakage
確保操作安全性 Ensure safe and efficient operation ☑ 電槽材質 Container Material : <ul style="list-style-type: none"> NP2.3-12 難燃等級UL94HB Flame class : UL94HB NP2.3-12FR 難燃等級UL94V0 Flame class : UL94V0 ☑ 用途 Applications :
UPS 不斷電系統、電信、緊急照明、警報系統、儀器、太陽能發電系統
UPS(Uninterruptible Power Supply)、Telecommunications、Emergency lighting、Alarm systems、Instrumentation、Solar powered systems |
|---|--|

NP2.3-12 性能規格 PERFORMANCE SPECIFICATION : 安培 Amperes and 瓦特 Watts at 25 °C (77 °F)

F.V.	TIME	3M	5M	6M	8M	10M	15M	30M	1H	2H	3H	5H	10H	20H
		10.80V	W	109	91	85	71	63	47.7	28.6	16.3	9.70	6.93	4.75
	A	9.8	8.0	7.4	6.3	5.5	4.09	2.43	1.37	0.80	0.57	0.39	0.21	0.116
10.50V	W	122	97	89	75	65	48.8	29.1	16.5	9.80	7.00	4.79	2.57	1.418
	A	10.7	8.5	7.8	6.5	5.7	4.19	2.47	1.39	0.81	0.58	0.39	0.21	0.117
10.20V	W	129	102	92	77	67	49.6	29.5	16.7	9.86	7.04	4.81	2.58	1.423
	A	11.7	9.0	8.1	6.8	5.9	4.26	2.51	1.40	0.82	0.58	0.40	0.21	0.117
10.02V	W	131	103	93	78	68	50.0	29.7	16.8	9.89	7.06	4.82	2.58	1.424
	A	12.0	9.2	8.2	6.9	5.9	4.30	2.52	1.41	0.82	0.58	0.40	0.21	0.117
9.60V	W	134	104	94	79	69	50.4	29.9	16.9	9.91	7.08	4.83	2.59	1.425
	A	12.4	9.4	8.4	7.0	6.0	4.33	2.54	1.42	0.82	0.59	0.40	0.21	0.117

特性 Characteristics

放電特性 DISCHARGE CHARACTERISTICS

放電曲線 Discharge Characteristics Curves at 25°C

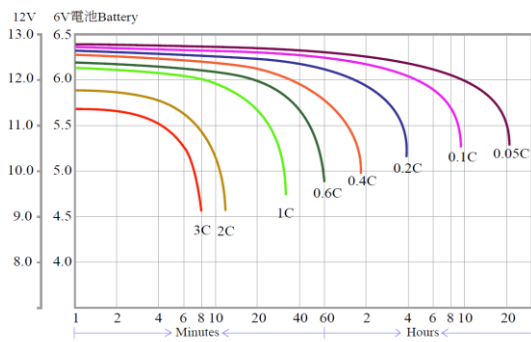

浮充期待壽命 Float Service Life

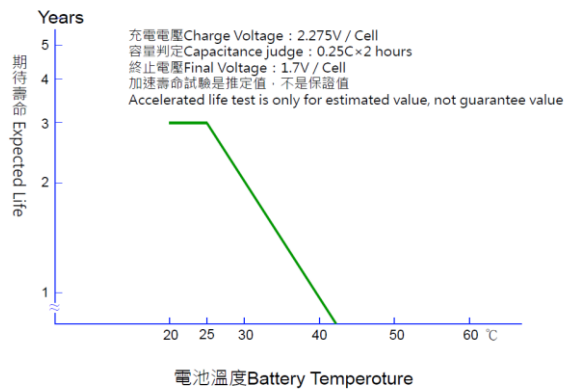

充電特性 CHARGE CHARACTERISTICS

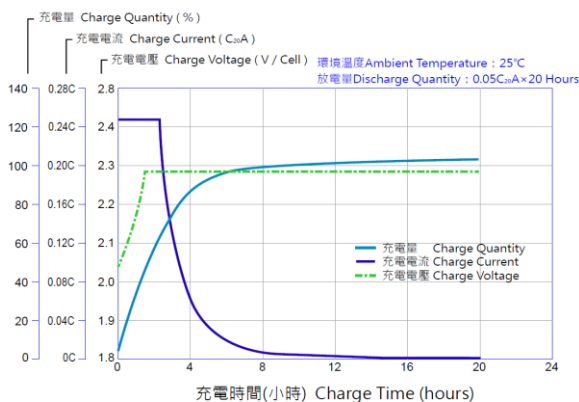

充電電壓 CHARGE VOLTAGE

