



型式 Model.	U1-36E-12		
首版日期 Initial Date.	2003.07.10	核准 Authorized.	作成 Author.
改訂日期 Revision Date.	2012.02.15	劉兆偉	曾寵惠

## 電池規格 BATTERY SPECIFICATIONS

### 閥調式鉛酸蓄電池 Valve Regulated Lead Acid (VRLA) Rechargeable Battery

1. 型式 Model : U1-36E-12
2. 額定電壓 / 容量 Nominal Voltage / Capacity : 12V / 36AH ( 20 HR )
3. 諸元 Mechanical Spec :

尺寸 Measurements	長 Length	196±2mm
	寬 Width	130±2mm
	槽高 Case height	158±3mm
	總高 Overall height	169±3mm
端子 Terminal	螺絲式 Bolt ( M5 ) 鎖緊轉矩 Tightening torque 2.0~3.0Nm ( 20~30kgf · cm )	
重量 Weight	約 About 11.2 kg	
ABS難燃等級 ABS Flame class	難燃等級UL94HB Flame class UL94HB	

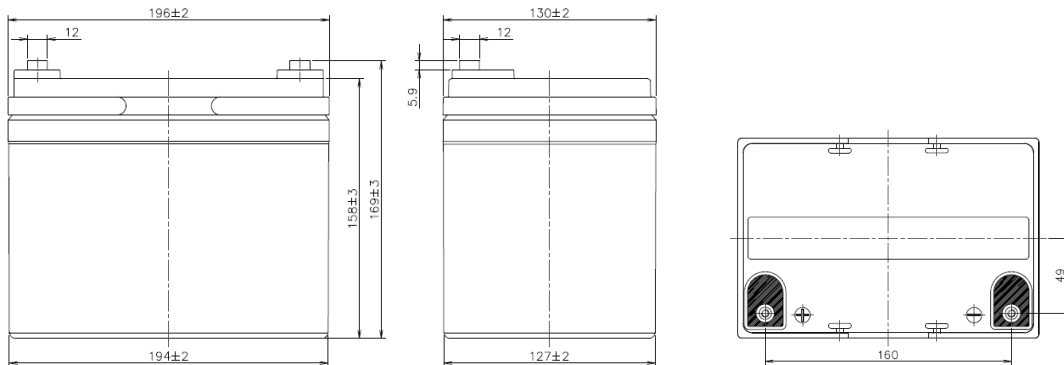

#### 4. 構造 Construction :

蓄電池係由陽極板、陰極板、電槽、蓋、隔離板、電解液等組成,並設有陽、陰極板引出端子。  
密閉構造機能為蓄電池產生之氣體由陰極板吸收且不必補水。

This battery is composed of positive plates, negative plates, separators, container, lid, electrolyte etc., and is equipped with positive and negative polarity terminals.  
Any emitted gas from the battery is minimized with the negative plate gas recombinant method, thus requiring no topping up of electrolyte.

## 5. 外觀 External appearance :

不得有漏液、污垢、裂痕、變形等現象。

Battery shall be without acid leakage, conspicuous stain, scar or deformation.

## 6. 性能 Performance :

6-1 性能測試溫度：25±2°C (特別指定不在此限)

6.1 Temperature of tested battery shall be 25±2°C, if not specified.

## 6-2 放電容量 Discharge capacity : (此數值為最小值 This value is the minimum)

PERFORMANCE DATA AT 25°C (77°F) - Amperes and Watts														
TIME F.V.		5M	10M	15M	20M	30M	45M	1H	2H	3H	4H	5H	10H	20H
	10.8V	W	1200	860	690	569	428	317	253.4	147.9	105.6	84.5	71.8	38.4
A		107	76	59	49.2	36.8	27.1	21.5	12.41	8.80	7.04	5.98	3.19	1.78
10.5V	W	1270	920	714	584	436	320	254.2	148.4	106.0	84.8	72.0	38.6	20.9
	A	115	82	62	50.8	37.6	27.4	21.6	12.46	8.85	7.08	6.02	3.21	1.80
10.2V	W	1350	970	733	596	442	322	254.5	148.9	106.6	85.2	72.4	38.8	21.1
	A	124	88	64	52.1	38.3	27.7	21.6	12.48	8.87	7.09	6.03	3.22	1.81
9.6V	W	1470	1000	746	604	446	324	255.0	150.6	108.2	86.6	73.6	39.5	21.2
	A	139	91	66	52.9	38.8	27.9	21.7	12.63	9.01	7.21	6.13	3.28	1.81

蓄電池交貨時，經完全充電〔電壓14.4V/只 (MAX. 0.25C<sub>20</sub>) 充電16hr〕後，1天內測試時仍須視電池充電狀態，必要時須延長充電時間。

The battery capacity at the time of delivery, within 1 day after being charged at 14.4V (MAX. 0.25C<sub>20</sub>) for 16hr.

Charge period may need to be extended, as it is dependent on the state of the charge of the battery.

## 6-3 開路電壓 Open circuit voltage :

在完全充飽電的狀態，開路電壓大約13V。

Open circuit voltage will be around 13 V at fully charged condition.  
It is dependent on the state of the charge of the battery.

## 6-4 內部電阻 Internal resistance :

完全充電後以AC橋式(1KHz)測試約8.7mΩ。

Give a full charge to the battery, and measure with AC bridge (1KHz), about 8.7mΩ.

## 6-5 最大連續放電電流 Maximum continuous discharge current :

360A放電5秒，電池不得有異常現象。

No deterioration shall be found with 360A discharge for 5 seconds.

## 6-6 充電 Charging :

充電方式 Method	電壓設定 Given Voltage	充電最大電流 Maximum charging Current	說 明 Special condition(S)
浮動充電 Float Charging	13.65V±0.15V	0.25C <sub>20</sub> ( A )	當環境溫度上升時，充電電壓必須降低避免造成過充電。因此建議以-3mV/°C/cell ( 25°C 基準值 ) 做溫度校正補償。 As the average ambient temperature rises, charging voltage should be reduced to prevent overcharge. Accordingly, the recommended compensation factor is -3mV/°C/cell at 25°C of standard centre point.
循環充電 Cyclic Charging	14.4V~15.0V	0.25C <sub>20</sub> ( A )	當環境溫度上升時，充電電壓必須降低避免造成過充電。因此建議以-4mV/°C/cell ( 25°C 基準值 ) 做溫度校正補償。 注意：為了避免造成電池過量的充電，導致電池的故障損壞，這種充電方式必須適當的終止電池充電時間。 As the average ambient temperature rises, charging voltage should be reduced to prevent overcharge. Accordingly, the recommended compensation factor is -4mV/°C/cell at 25°C of standard centre point. Caution : This needs to be terminated with appropriate charging period in order to avoid excess over charging that can result in the damage of the batteries.

## 6-7 使用溫度範圍 Permissible temperature range :

狀態 Conditions	溫度範圍 Temperature range
放電 Discharging	-15°C ~ 50°C
充電 Charging	0°C ~ 40°C
放置 Storage	-15°C ~ 40°C

## 6-8 放置期限 Storage period without charge :

溫度狀況 Storage temperature	容許放置期限 Max. storage period
Temp. ≤ 25°C	6 個月 months
25 < Temp. ≤ 30°C	4 個月 months
30 < Temp. ≤ 35°C	3 個月 months
35 < Temp. ≤ 40°C	2 個月 months

## 6-9 期待循環壽命 Expected Cyclic life :

## 50%放電測試條件 :

在環境溫度 $25\pm 2^{\circ}\text{C}$  · 以 $0.25\text{C}$  ( A ) 放電2小時。再以定電壓 $14.4\sim 14.7\text{V}$ /只充電 ( 充電電氣量=放電電氣量的 $105\sim 110\%$  ) · 期待循環壽命約600Cycle ( 放電末電壓應達 $10.2\text{V}$ 以上 ) 。

期待壽命會因溫度的升高而變得更短。

50% DOD test condition : ( at  $25\pm 2^{\circ}\text{C}$  )

Discharge at  $0.25\text{C}$  ( A ) for 2 hours. Constant voltage charge at  $14.4\sim 14.7\text{V}$  / battery ( Charge amount ( AH ) = $105\sim 110\%$  of discharge amount ( AH ) ) .

Expected cycle life about 600 cycle ( Final discharge voltage over  $10.2\text{V}$  ) .

Expected life will become shorter accordingly with rise in the temperature.

## 6-10 機械強度 Mechanical strength :

## 6-10-1 耐振動性能 :

振 幅 :  $4\text{ mm}$

頻 率 :  $16.7\text{ Hz}$ 任意方向連續60分鐘振動後,目視檢查電池不得有漏液、異常現象,測定電壓應達 $12\text{V}$ 以上。

## 6-10-2 耐衝擊性 :

在厚約 $10\text{mm}$ 以上之硬木板上測試,由 $20\text{cm}$ 高處落下(方向任意,但端子部除外)一次後,目視檢查不得漏液、異常現象,測定電壓應達 $12\text{V}$ 以上。

## 6-10-1 Anti-vibration performance :

Vibrate the battery in any directions for 60 consecutive minutes with  $4\text{ mm}$  amplitude and  $16.7\text{ Hz}$  per minute. Read the voltage and make visual inspection. Battery shall show no extreme damage or no electrolyte leakage and should read nominal  $12\text{V}$  or more.

## 6-10-2 Anti-impact performance :

Drop it from a  $20\text{cm}$  height onto a  $10\text{mm}$  thick solid wooden block in any directions except terminal portions. Read the voltage and make visual inspection. Battery shall show no extreme damage or no electrolyte leakage and should read nominal  $12\text{V}$  or more.

## 7. 安裝條件 Installation Conditions :

蓄電池的收納容器不得為密封構造，收納容器請務必設置通往外部的通氣孔。

若在金屬製的收納容器內使用蓄電池，則為了避免蓄電池因電槽（外殼）破裂而產生漏液，導致收納容器或固定架與蓄電池之間形成漏電迴路，請在兩者之間配置具耐熱、耐酸性且不會因固定時的應力而造成破損的絕緣片或絕緣匣，或者將蓄電池裝入絕緣袋中。

上述絕緣物請使用不會在表面附著油脂類、或由絕緣物內部滲出有機物之絕緣物。

蓄電池請勿與含有可塑劑的乙烯絕緣帶、絕緣片或溶劑、油脂等接觸。

Storage container for rechargeable battery must not be of sealed and air tight construction; the container must be equipped with appropriate ventilation system, such as ventilation holes leading to the outside and so on.

The following applies to using a rechargeable battery inside a metallic storage box: to prevent the rechargeable battery from leaking fluid due to a breakage in the electrolytic cell, thus forming a leak circuit between the battery and the storage box (or fixed frame), install between these two items a heat and acid resistant insulating sheet (or tray) that will not be damaged by periodic stress. Alternatively, place the rechargeable battery inside an insulating bag but not to be sealed.

For the above described insulation material, do not use any material that can be stained with grease, or that can have organic substance oozing out of itself.

Do not allow the rechargeable battery to come into contact with vinyl tape containing plasticizer, insulation sheet, solvent, or grease.

## 8. 注意 Caution :

請避免不同種類、容量、批號電池串聯，或並聯組數超過三組以上。

It is not recommended to use different kinds of batteries or capacities or lot numbers in series string connections.

It is not recommended to use more than 3 parallel string connections.

## 9. 變更履歷 Modification record :

版次 Revision	日期 Date	變更內容 Modification content
5	2012.02.15	增訂9.變更履歷。 Increase Item 9.0 modification record.